



Congratulations on the purchase of your new DMI Sports Pool table. Our products are designed and manufactured to give you years of game playing enjoyment.

KEEP BOX AND PACKING MATERIAL UNTIL TABLE HAS BEEN COMPLETELY ASSEMBLED.

ALL DAMAGE MUST BE REPORTED TO DMI WITHIN TEN DAYS OF RECEIPT.

If you have any problems with your new product,

PLEASE DO NOT RETURN IT TO THE STORE.

Please contact us:

1.800.399.4402

FAX: 215.283.9573

Please have your model number when inquiring about parts.

Or write to:

DMI Sports

Customer Service

375 Commerce Drive

Fort Washington PA, 19034

Please visit our web site at:

www.dmisports.com

When contacting DMI Sports, please provide your model number and item number (if applicable) if requesting a replacement part. Item numbers can be found inside this owners manual.

Your Model Number **MFT150CT**

Your model number is also located on the original carton. These instructions are also available online at: www.dmisports.com.

IMPORTANT!

Please Keep Your Instructions! (You will need your Model number should you need to contact us.) Before attempting assembly, please read through this instruction book to familiarize yourself with all the parts and assembly steps. We recommend that two adults assemble this table. Please refer to the Parts Identifier on the following page and be sure that all parts have been included. Although extremely rare, occasionally a part may be missing. If you are missing a part, or if you have any questions, please call our customer service department at 1.800.399.4402 Mon-Fri between the hours of 9:00am and 5:00pm E.S.T; or you can reach us at: www.dmisports.com.







Do not return the game to the store. Please contact us first at: 1.800.399.4402 or on our website at: www.dmisports.com.

TWO ADULTS ARE REQUIRED TO ASSEMBLE THIS POOL TABLE













PARTS IDENTIFIER





HARDWARE PARTS

H1	Qty. 8	H2	Qty. 8	H3	Qty. 16	H4	Qty. 12
							
8x30mm Wing Bolt RPMFT150-30BOLT		22mm Flat Washer RPMFT150-22WASH		4x18mm Wing bolt RPMFT150-18BOLT		4x16mm Wing Bolt RPMFT150-16BOLT	
H5	Qty. 28	H6	Qty. 8				
							
16mm Flat Washer RPMFT150-16WASH		Plastic Dowel RPMFT150-DOWEL					

ASSEMBLY PARTS

P1	Qty. 1	P2	Qty. 2	P3	Qty. 2	P4	Qty. 2
							
Table Assembly RPMFT150-TABLE		Side Apron RPMFT150-SAPRON		End Apron RPMFT150-EAPRON		Right Leg RPMFT150-RLEG	
P5	Qty. 2	P6	Qty. 2	P7	Qty. 2	P8	Qty. 4
							
Left Leg RPMFT150-LLEG		End Panel RPMFT150-EPANEL		Side Brace RPMFT150-BRACE		Apron Corner RPMFT150-CORNER	
P9	Qty. 4	P10	Qty. 1	P11	Qty. 1		
							
Leg Leveler RPMFT150-LEV		Table Tennis Net Set MFCT-150NP		Conversion Top MFCT-150			

ACCESSORY PARTS

A1	Qty. 1	A2	Qty. 2	A3	Qty. 1	A4	Qty. 2
							
Triangle MFA40993		Chalk MFA42405		Billiard Ball MFA41655		2 Piece Billiard Cues MFR40432	

ASSEMBLY

STEP 1.

Attach the Side Aprons (P2) and the End Aprons (P3) to the Table Assembly (P1) using hardware parts (H4) and (H5) as shown in FIG 1.1.

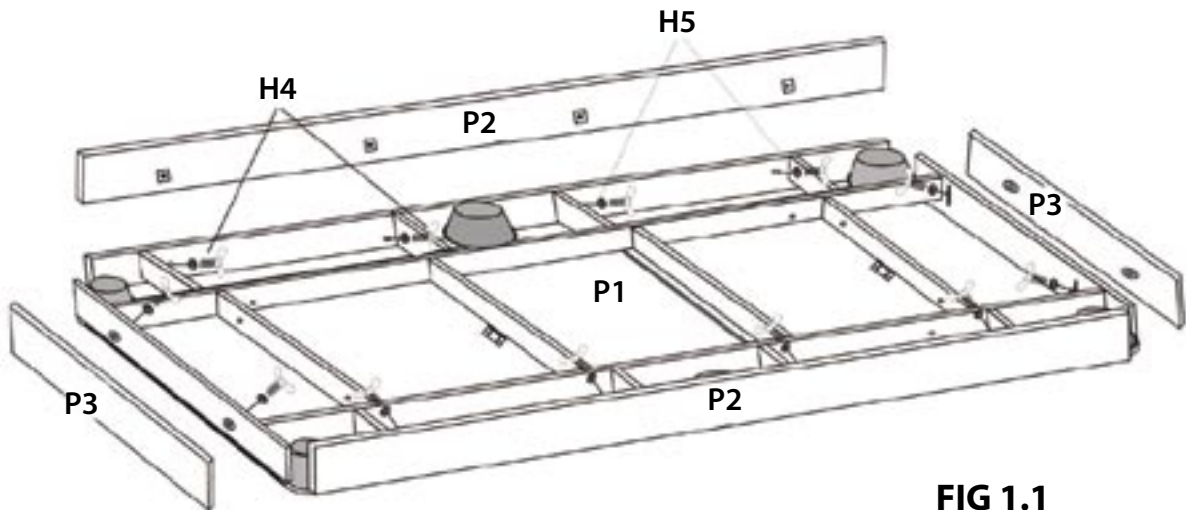

FIG 1.1

STEP 2.

Attach Apron Corners (P8) to the ends of the Side & End Aprons using hardware parts (H6) as shown below in FIG 2.1.

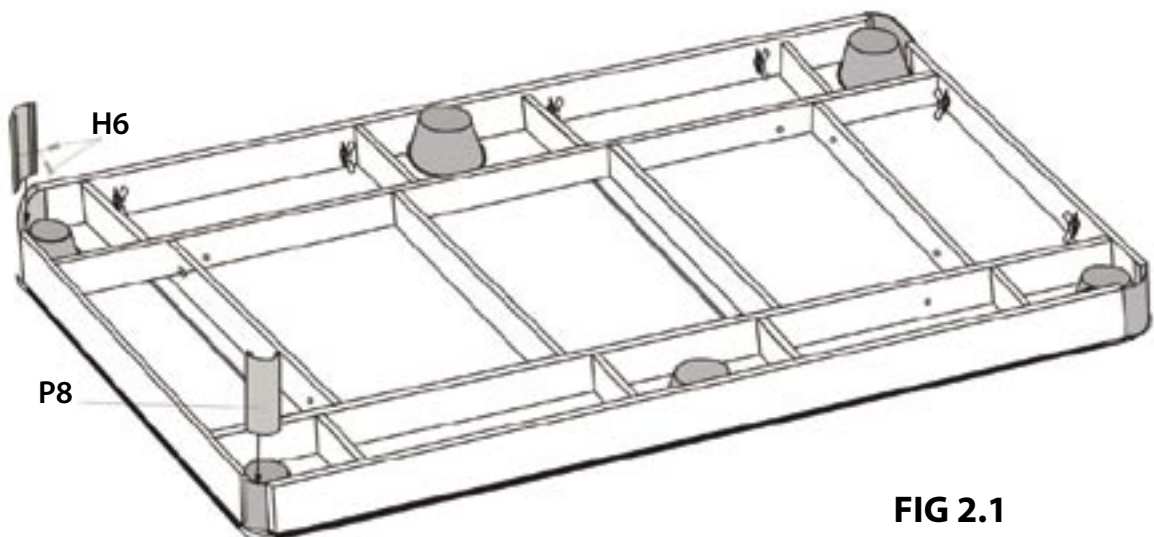

FIG 2.1

ASSEMBLY

STEP 3.

Attach Right Leg (P5) and Left Leg (P4) to the End Panel (P6) using hardware parts (H3) and (H5). Now attach the two Side Braces (P7) to the legs and end panels as shown below in FIG 3.1. Once the legs, end panels and side braces are assembled, attach them to the table assembly using hardware parts (H1) and (H2) also shown below in FIG 3.1. Attach the Leg Levelers (P9) to each of the four legs before turning the table over.

IMPORTANT!

Remember, your table is up-side-down. The left leg will be on your right and vice-versa while up-side-down.

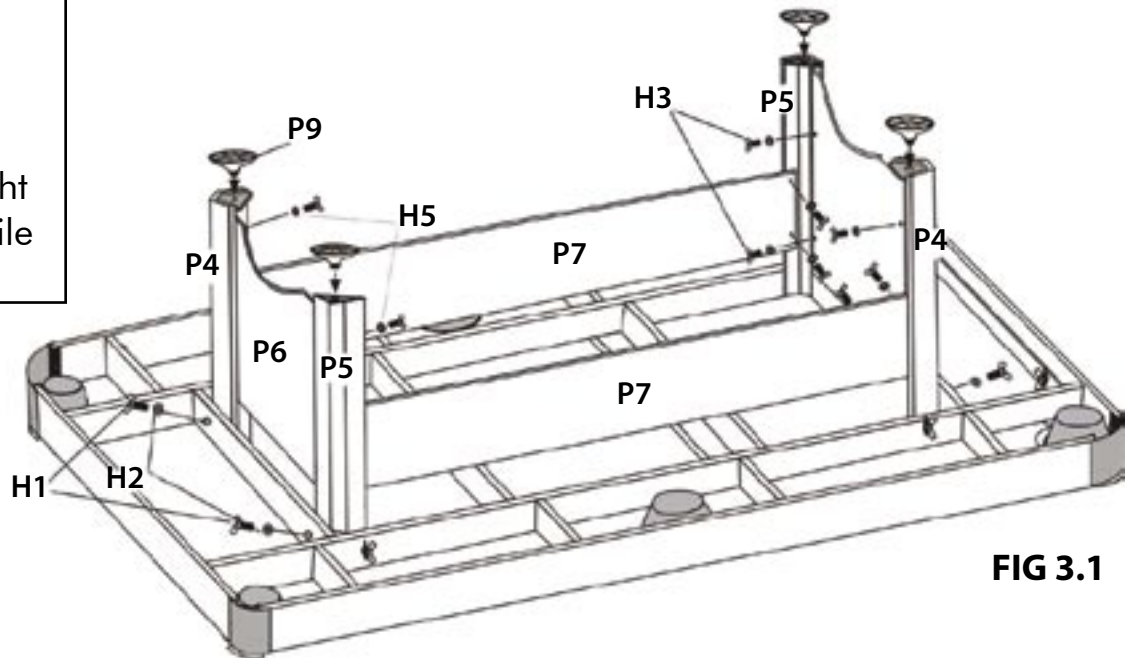
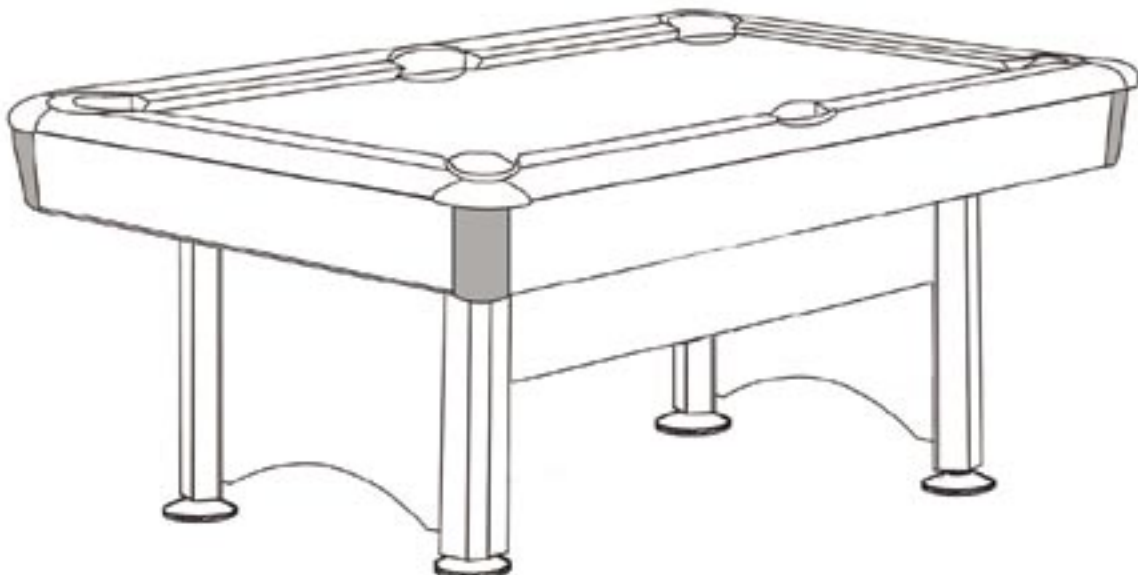

FIG 3.1

STEP 4.

When the table is complete and in it's final location, we suggest that you make sure the table is level. Please refer to the instructions for leveling a pool table on the following page.



INSTRUCTIONS FOR LEVELING A POOL TABLE

- Assemble pool table according to the instructions, making sure levelers are screwed in completely, then turning one full turn out.
- Any type of level would be sufficient to perform this procedure. However, a two-foot level is recommended.
- Before leveling, make sure level is placed on the playing surface, not the rails.
- Level the ends between the corner pockets. Place the level on the playing surface between the two corner pockets and adjust the levelers in or out to position the bubble in the middle of the level.
- Repeat the step above to the opposite corner pockets.
- Next, level the length of the table. Place the level next to the side pocket and adjust the levelers in or out to position the bubble in the middle of the level.
- Repeat the step above to the opposite length of the table.
- Recheck both short ends to ensure bubble is in the middle on the level.
- Depending on the surface the pool table sits, especially deep pile carpeting, the pool table needs to settle for 24 hours. Recheck the level on each side of the table after 24 hours.
- These same instructions may be followed to level hockey and soccer table play surfaces as well.

